

DIMENSIONI DI INGOMBRO

UTN-BL – VERSIONE MONOBLOCCO

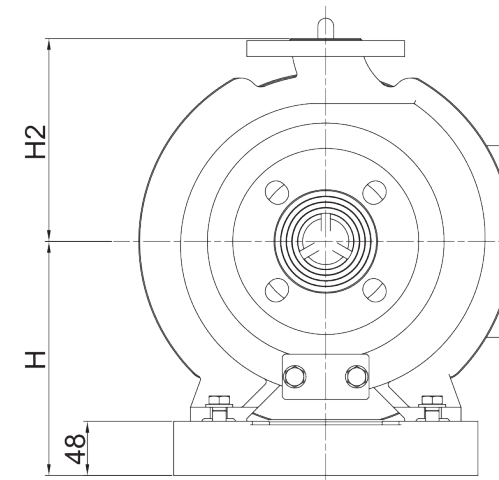
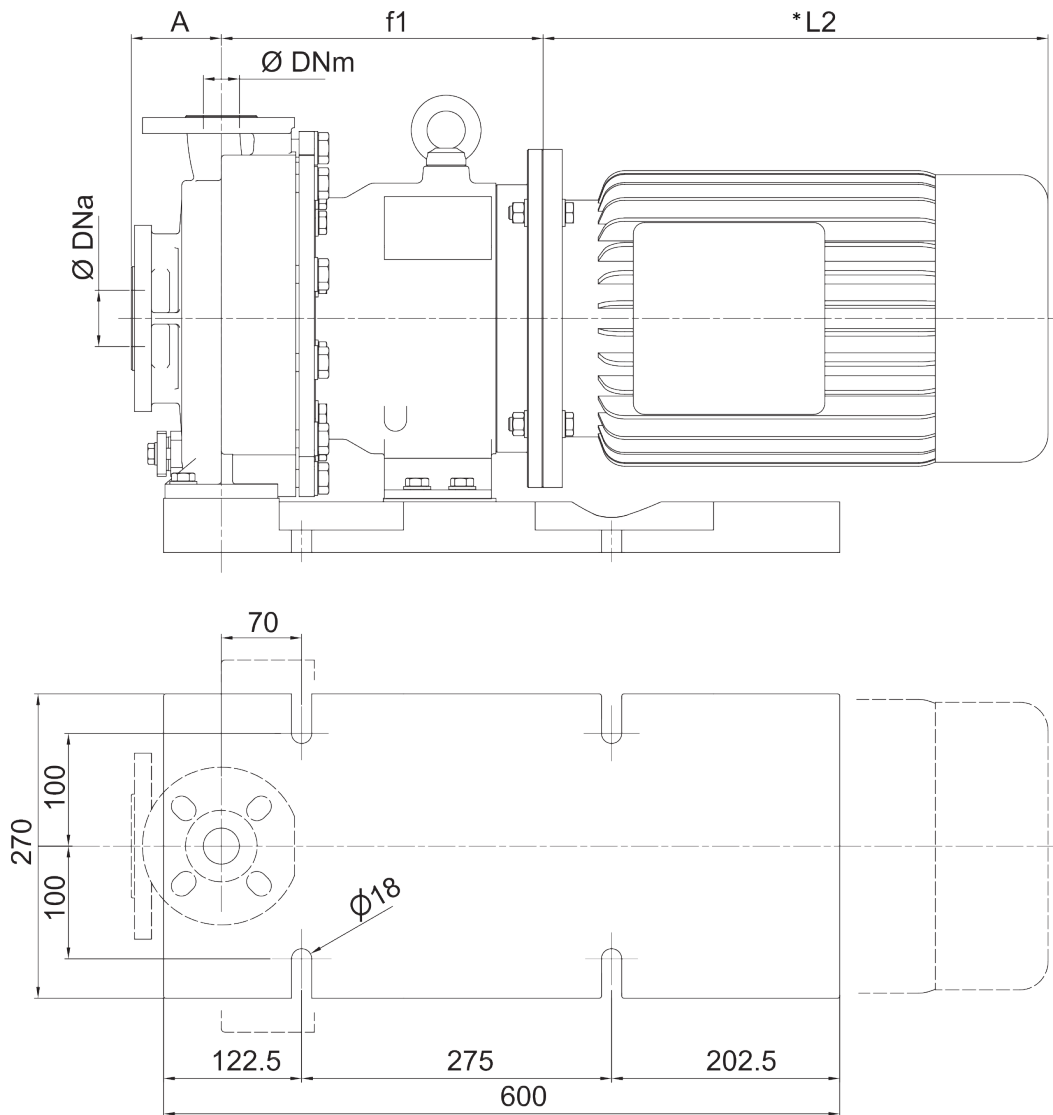

Modello Pompa	Peso senza Motore
UTN-BL 40-25-160	40kg
UTN-BL 50-32-160	45kg
UTN-BL 65-40-160	50kg
UTN-BL 80-50-125	55kg
UTN-BL 80-50-160	60kg
UTN-BL 50-32-200	75kg
UTN-BL 65-40-200	80kg
UTN-BL 80-50-200	85kg

Grandezza Motore	f1	Forma
	mm	
80	257	B5
90	257	
100	257	
112	257	
132	287	
160	305	

Modello Pompa	Dna		DNm		A	H	H2	
	mm		mm		mm	mm	mm	
UTN-BL 40-25-160	40	UNI EN 1092-1 PN 16RF Asolate ANSI 150	25	UNI EN 1092-1 PN 16RF Asolate ANSI 150	80	180	160	
UTN-BL 50-32-160	50		32					
UTN-BL 65-40-160	65		40					
UTN-BL 80-50-125	80		50		100	180**		
UTN-BL 80-50-160	80		50		100	208		180
UTN-BL 50-32-200	50		32		80			
UTN-BL 65-40-200	65		40		100			
UTN-BL 80-50-200	80		50				200	

** Per la grandezza 125 grandezza motore 160: H = 208

* Per la dimensione L2 fare riferimento al costruttore del motore

DIMENSIONI DI INGOMBRO

UTN-L – VERSIONE ASSE NUDDO

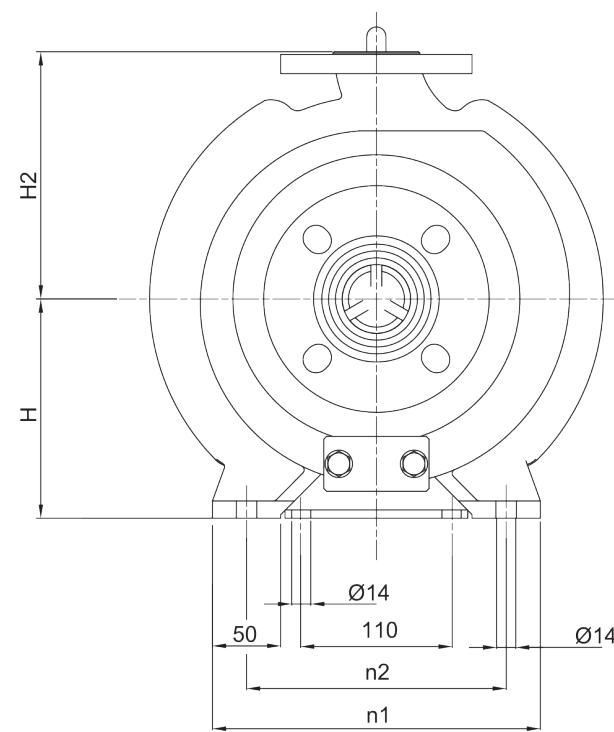
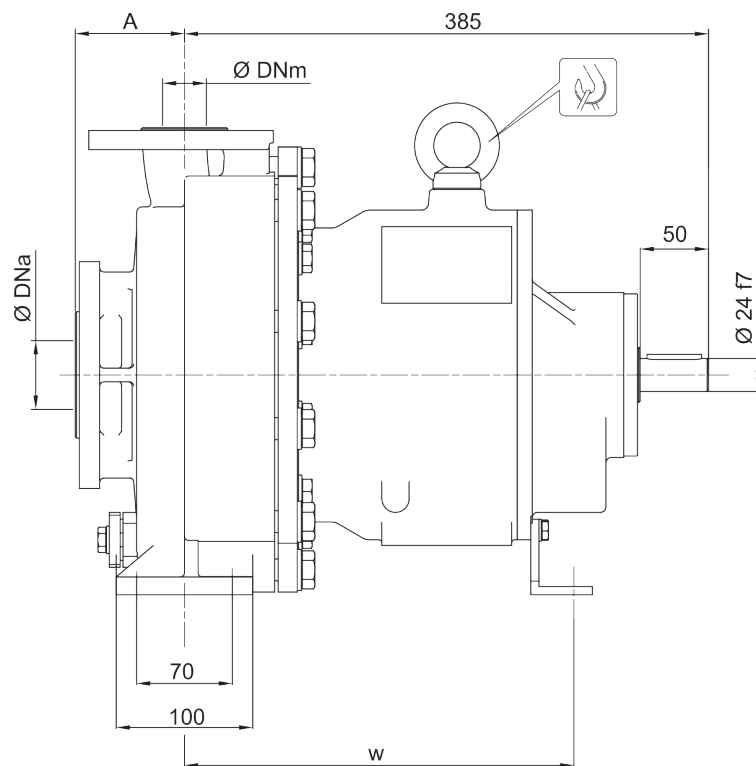

Modello Pompa	ØDna		ØDNm		A	w	H	H2	n1	n2
					mm	mm	mm	mm	mm	mm
UTN-L 40-25-160	40	UNI EN 1092-1 PN 16RF Asolate ANSI 150	25	UNI EN 1092-1 PN 16RF Asolate ANSI 150	80	285	132	160	240	190
UTN-L 50-32-160	50		32							
UTN-L 65-40-160	65		40							
UTN-L 80-50-125	80		50		100		160	180	240	190
UTN-L 80-50-160	80		50		100					
UTN-L 50-32-200	50		32		80					
UTN-L 65-40-200	65		40		100		200	265	212	
UTN-L 80-50-200	80		50							

Modello Pompa	Peso senza Motore
UTN-L 40-25-160	40kg
UTN-L 50-32-160	45kg
UTN-L 65-40-160	50kg
UTN-L 80-50-125	55kg
UTN-L 80-50-160	60kg
UTN-L 50-32-200	75kg
UTN-L 65-40-200	80kg
UTN-L 80-50-200	85kg

*Per la dimensione L4 fare riferimento al costruttore del motore

DIMENSIONI DI INGOMBRO

UTN-L – ESECUZIONE SU BASE

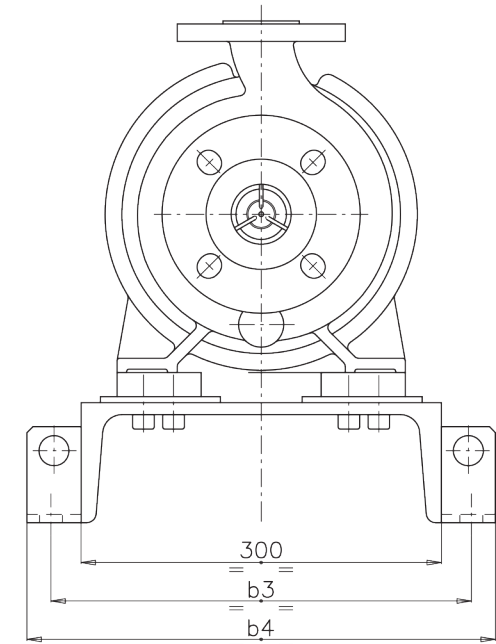
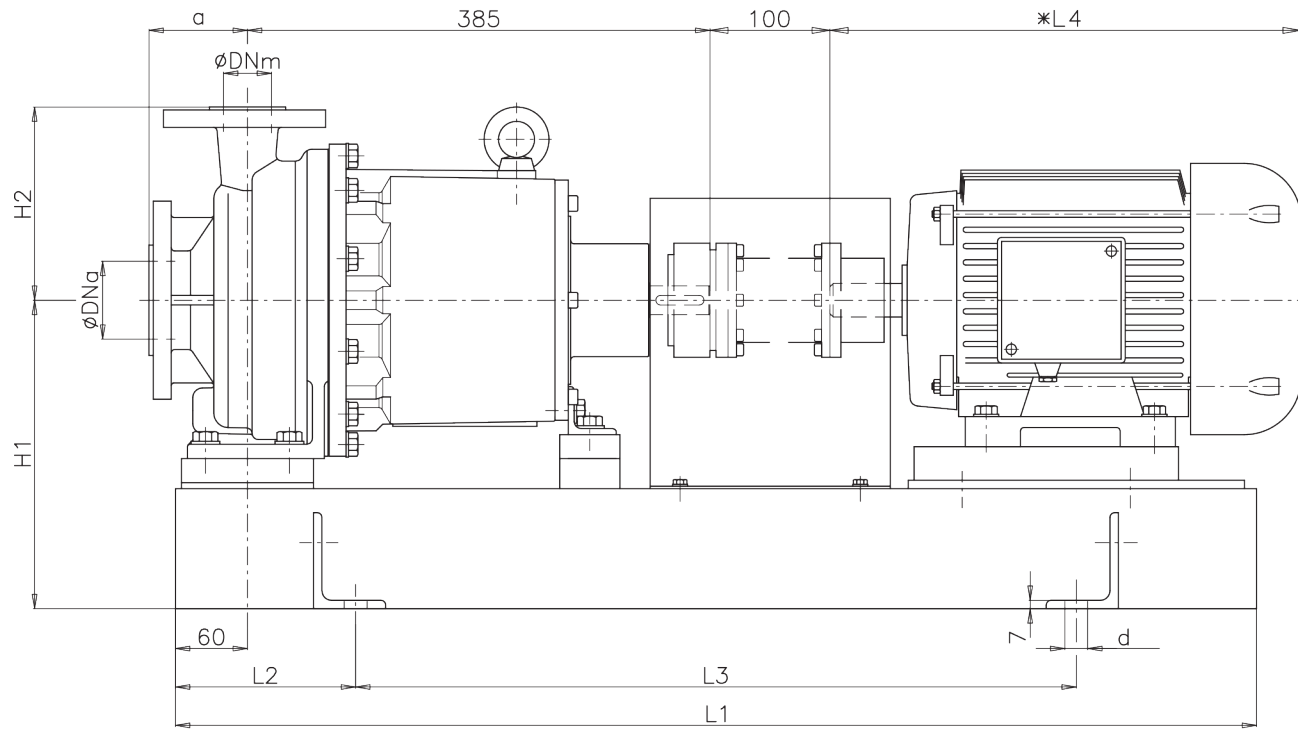

Installazione su base					Grandezza Motore					
					90	100	112	132	160	180
Modello Pompa	DNa UNI EN 1092-2 PN 16RF Asolate ANSI 150	DNm UNI EN 1092-2 PN 16RF Asolate ANSI 150	a	H2	H1					
	∅	∅	mm	mm	mm	mm	mm	mm	mm	mm
UTN-L 40-25-160	40	25	80	165	257	257	257	272	272	292
UTN-L 50-32-160	50	32		160	257	257	257	272	272	292
UTN-L 65-40-160	65	40		180	270	270	270	300	300	300
UTN-L 80-50-125	80	50		160	257	257	257	272	272	292
UTN-L 80-50-160	80	50	100	180	270	270	270	300	300	300
UTN-L 50-32-200	50	32		180	270	270	270	300	300	300
UTN-L 65-40-200	65	40		160	257	257	257	272	272	292
UTN-L 80-50-200	80	50		200	270	270	270	300	300	300

Grandezza Motore	L1	L2	L3	b3	b4	d
	mm	mm	mm	mm	mm	∅ mm
80-90 100-112	900	150	600	350	390	19
132	1000	170	660	400	450	24
160-180	1120	190	740	440	490	24

* Per la dimensione L4 fare riferimento al costruttore del motore



I dati indicati su questa pagina non sono da ritenersi vincolanti.