

UCL

Overall dimensions

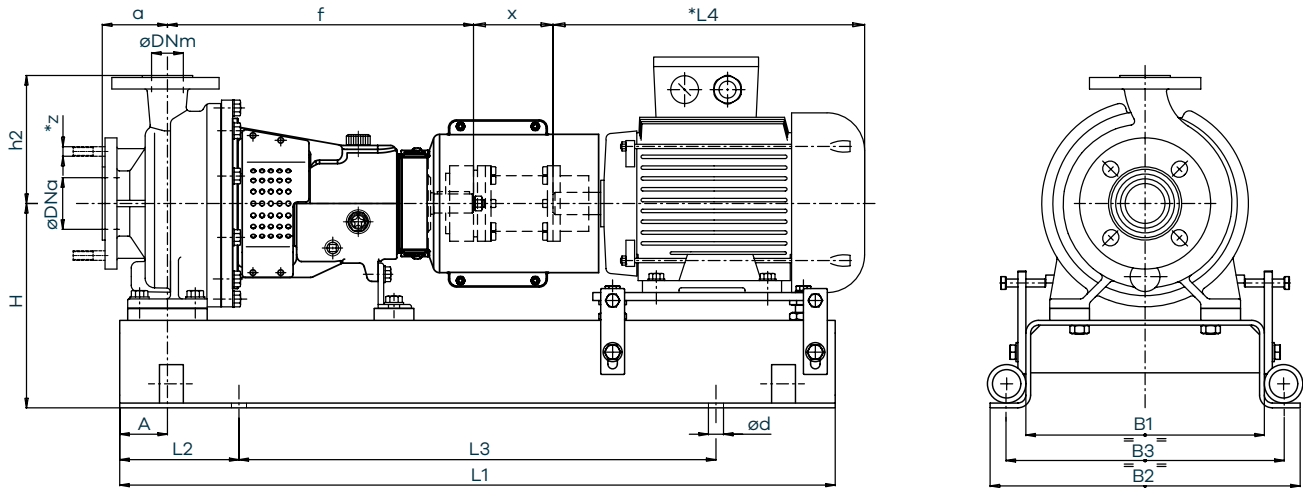

Pump dimensions:

Model	25-25-125	40-25-160	50-32-160	65-40-160	80-50-125	80-50-160	50-32-200	65-40-200	80-50-200
DNa ø	25	40	50	65	80	80	50	65	80
	UNI EN 1092-1 PN 10RF slotted ANSI 150								
DNm ø	25	25	32	40	50	50	32	40	50
	UNI EN 1092-1 PN 10RF slotted ANSI 150								
a (mm)	80	80	80	80	100	100	80	100	100
A (mm)	60	60	60	60	60	60	60	60	60
f (mm)	385	385	385	385	385	385	385	385	385
h2 (mm)	160	160	160	160	160	180	180	180	200
x (mm)	100	100	100	100	100	100	100	100	100
H - motor size	80 (mm)	257	257	257	257	257	285	285	285
	90 (mm)	257	257	257	257	257	285	285	285
	100 (mm)	257	257	257	257	257	285	285	285
	112 (mm)	257	257	257	257	257	285	285	285
	132 (mm)	272	272	272	272	272	300	300	300
	160 (mm)	272	272	272	272	272	300	300	300
180 (mm)							300	300	300
Pump weight (without motor)	40	40	41	44	46	48	52	56	60

Base dimensions:

Motor Size	B1 (mm)	B2 (mm)	B3 (mm)	ød (mm)	L1 (mm)	L2 (mm)	L3 (mm)	Base weight (without motor)
80-90-100-112	300	390	350	M16	900	150	600	45
132	340	450	400	M20	1000	170	660	58
160-180	380	490	440	M20	1120	190	740	90

*L4 = the size depends on the manufacturer of the motor installed | *z = DNm 80 equipped with 4 M16x60 studs for ANSI 150

UCL

Overall dimensions

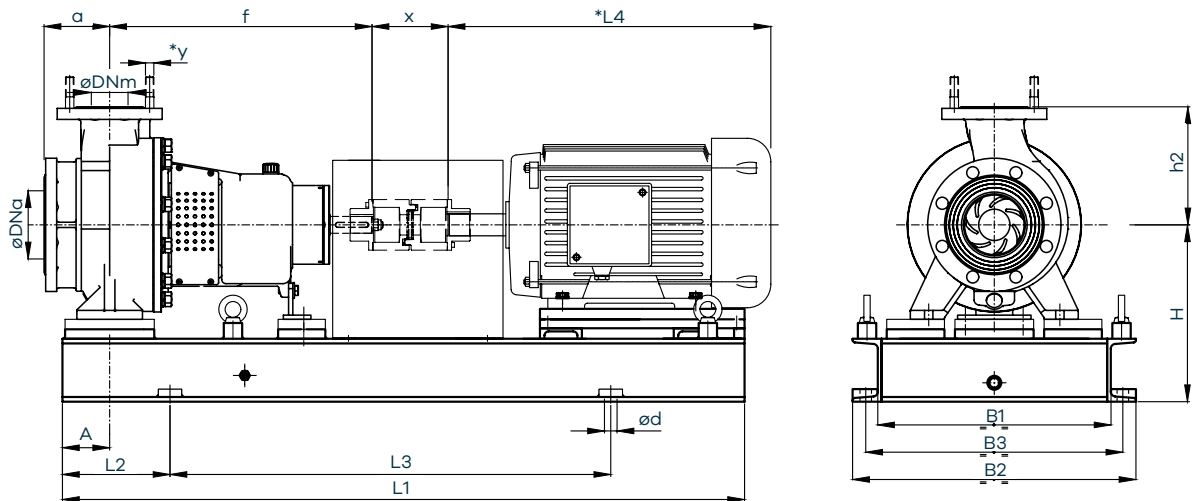

Pump dimensions:

Model	125-80-160	125-80-200
DNa Ø	125	125
	UNI EN 1092-1 PN 16RF slotted ANSI 150	
DNm Ø	80	80
	UNI EN 1092-1 PN 16RF slotted ANSI 150	
a (mm)	125	125
A (mm)	75	75
f (mm)	500	500
h2 (mm)	225	250
x (mm)	140	140
H - motor size	132 (mm)	298
	160 (mm)	318
	180 (mm)	318
	200 (mm)	358
	225 (mm)	383
	250 (mm)	403
Pump weight (without motor)	100	115

Base dimensions:

Motor Size	B1 (mm)	B2 (mm)	B3 (mm)	Ød (mm)	L1 (mm)	L2 (mm)	L3 (mm)	Base weight (without motor)
132	402	490	440	M20	1120	190	740	80
160-180	444	540	490	M20	1300	205	840	100
200-225	480	610	550	M24	1400	230	940	130
250	554	660	600	M24	1600	270	1060	170

*L4 = the size depends on the manufacturer of the motor installed | *z = DNm 80 equipped with 4 M16x60 studs for ANSI 150

UCL

Overall dimensions

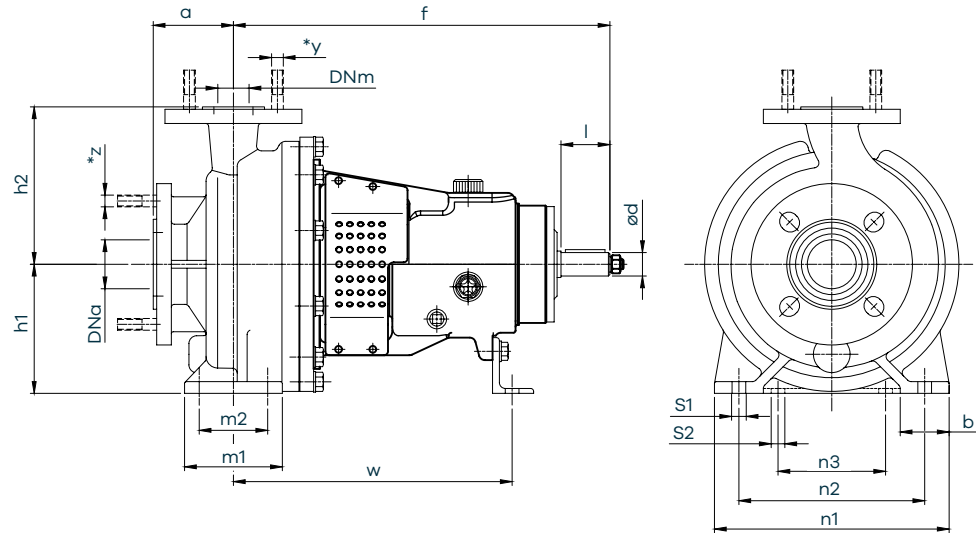

Pump dimensions:

Model	25-25-160	40-25-160	50-32-160	65-40-160	80-50-125	80-50-160	50-32-200	65-40-200	80-50-200	125-80-160	125-80-200
DNa Ø	25	40	50	65	80	80	50	65	80	125	125
	UNI EN 1092-1 PN 10RF slotted ANSI 150										
DNm Ø	25	25	32	40	50	50	32	40	50	80	80
	UNI EN 1092-1 PN 10RF slotted ANSI 150										
a (mm)	80	80	80	80	100	100	80	100	100	125	125
b (mm)	50	50	50	50	50	50	50	50	50	65	65
ød (mm)	24	24	24	24	24	24	24	24	24	32	32
f (mm)	385	385	385	385	385	385	385	385	385	500	500
h1 (mm)	132	132	132	132	132	160	160	160	160	180	180
h2 (mm)	160	160	160	160	160	180	180	180	200	225	250
l (mm)	50	50	50	50	50	50	50	50	50	80	80
m1 (mm)	100	100	100	100	100	100	100	100	100	125	125
m2 (mm)	70	70	70	70	70	70	70	70	70	95	95
n1 (mm)	240	240	240	240	240	265	240	265	265	320	345
n2 (mm)	190	190	190	190	190	212	190	212	212	250	280
n3 (mm)	110	110	110	110	110	110	110	110	110	110	110
S1 (mm)	14	14	14	14	14	14	14	14	14	16	16
S2 (mm)	14	14	14	14	14	14	14	14	14	16	16
w (mm)	285	285	285	285	285	285	285	285	285	370	370
Pump weight (without motor)	40	40	41	44	46	48	53	56	60	100	115

*y = DNm 80 equipped with 4 M16x60 studs for ANSI 10

UCL-B

Overall dimensions

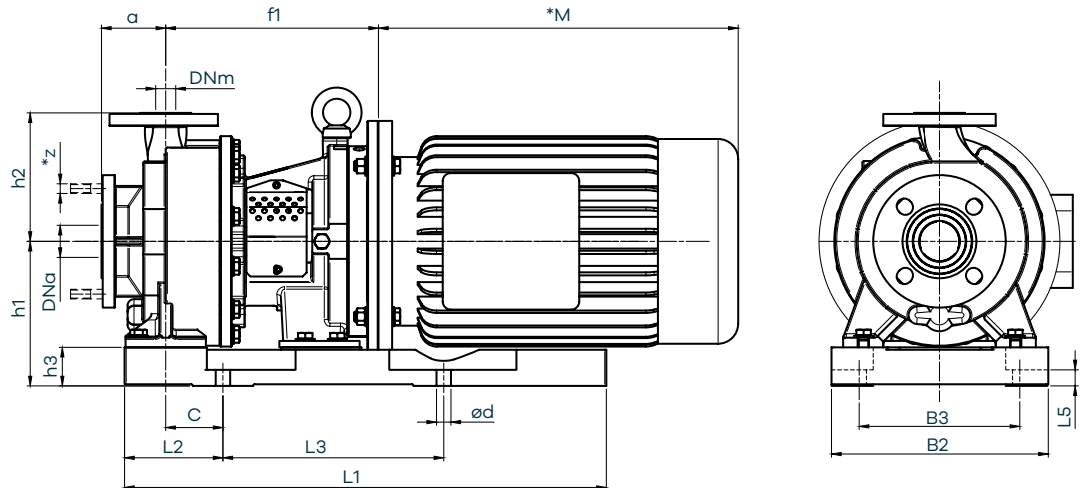

Pump dimensions:

Model	25-25-160	40-25-160	50-32-160	65-40-160	80-50-125	80-50-160	50-32-200	65-40-200	80-50-200
DNa Ø	25	40	50	65	80	80	50	65	80
	UNI EN 1092-1 PN 16RF slotted ANSI 150								
DNm Ø	25	25	32	40	50	50	32	40	50
	UNI EN 1092-1 PN 16RF slotted ANSI 150								
a (mm)	80	80	80	80	100	100	80	100	100
B2 (mm)	270	270	270	270	270	270	270	270	270
B3 (mm)	200	200	200	200	200	200	200	200	200
C (mm)	70	70	70	70	70	70	70	70	70
ød (mm)	18	18	18	18	18	18	18	18	18
h2 (mm)	160	160	160	160	160	180	180	180	200
h3 (mm)	48	48	48	48	48	48	48	48	48
L1 (mm)	550	550	550	550	550	550	550	550	550
L2 (mm)	123	123	123	123	123	123	123	123	123
L3 (mm)	275	275	275	275	275	275	275	275	275
L5 (mm)	20	20	20	20	20	20	20	20	20
90 (mm)	226	226	226	226	226	226	226	226	226
100 (mm)	235	235	235	235	235	235	235	235	235
112 (mm)	235	235	235	235	235	235	235	235	235
132 (mm)	265	265	265	265	265	265	265	265	265
160 (mm)	280	280	280	280	280	280	280	280	280
90 (mm)	180	180	180	180	180	208	208	208	208
100 (mm)	180	180	180	180	180	208	208	208	208
112 (mm)	180	180	180	180	180	208	208	208	208
132 (mm)	180	180	180	180	180	208	208	208	208
160 (mm)	208	208	208	208	208	208	208	208	208
Motor shape	B5	B5	B5	B5	B5	B5	B5	B5	B5
Pump weight (without motor)	40	40	41	44	46	48	52	56	60

*M dimension is according to installed motor manufacturer.