

# ETN evo

## Dimensioni d'ingombro

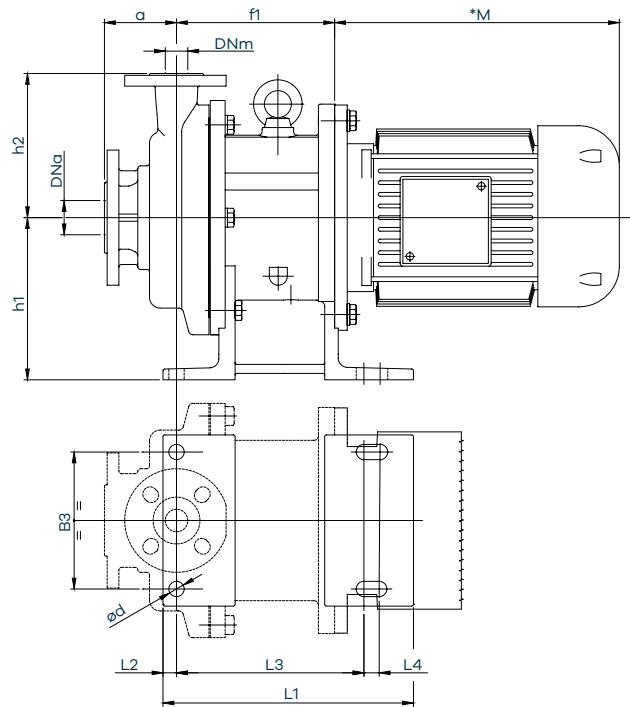
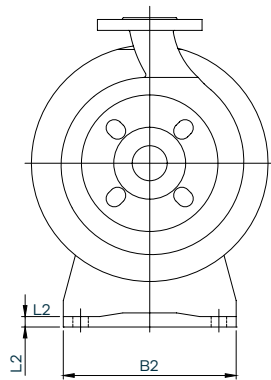

### Dimensioni pompa

Modello	ETN EVO 50 PP / ETFE	ETN EVO 60 PP / ETFE	ETN EVO 70 PP / ETFE
<b>DNa</b>	40	65	80
<b>DNm</b>	25	40	50
<b>a (mm)</b>	80	80	100
<b>B2</b>	190	190	190
<b>B3</b>	152	152	152
<b>ød</b>	17	17	17
<b>h1</b>	180	180	180
<b>h2</b>	160	160	160
<b>L1</b>	277	277	277
<b>L2</b>	15	15	15
<b>L3</b>	208	208	208
<b>L4</b>	17	17	17
<b>L5</b>	11,5	11,5	11,5

f1	ETN EVO 50 PP / ETFE	ETN EVO 60 PP / ETFE	ETN EVO 70 PP / ETFE
<b>Dimensioni motore</b>			
<b>80 (mm)</b>	175.5	175.5	175.5
<b>90 (mm)</b>	175.5	175.5	175.5
<b>100 (mm)</b>	175.5	175.5	175.5
<b>112 (mm)</b>	175.5	175.5	175.5
<b>132 (mm)</b>	193.5	193.5	193.5
<b>Forma motore</b>	<b>B5</b>	<b>B5</b>	<b>B5</b>
<b>Peso pompa (senza motore)</b>	32	32	37

\*L1 la dimensione è in accordo all'installazione del motore

\*\*Dimensioni flange secondo UNI 1092-2 ISO \ 7005-2 PN 16 RF tipo B - asolate ANSI 150 RF

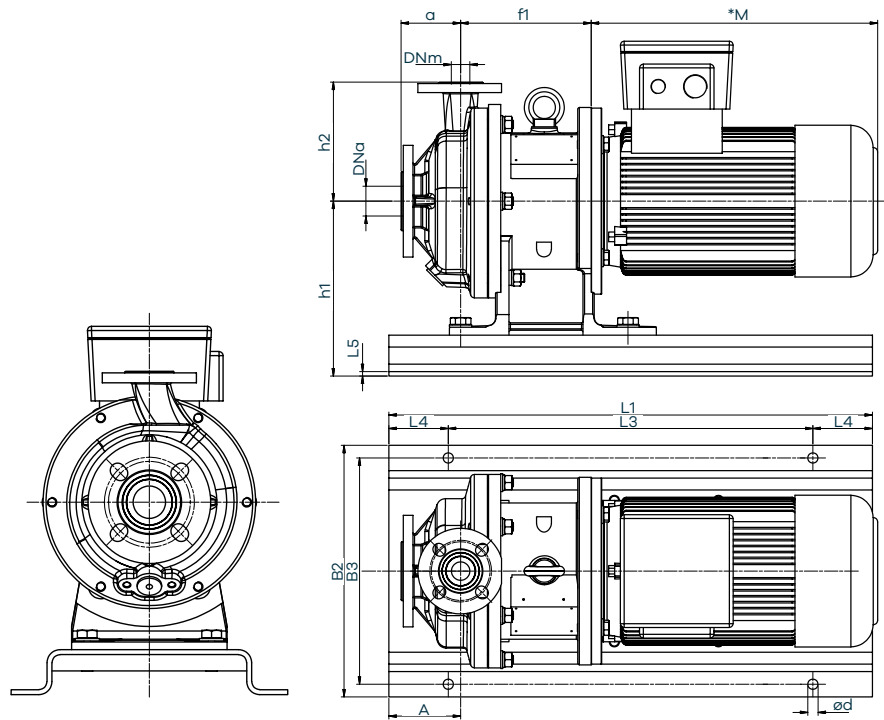

## Dimensioni pompa

Modello	ETN EVO 50 PP / ETFE	ETN EVO 60 PP / ETFE	ETN EVO 70 PP / ETFE
<b>DNa</b>	40	65	80
<b>DNm</b>	25	40	50
<b>a (mm)</b>	80	80	100
<b>A</b>	96,5	96,5	96,5
<b>B2</b>	338	338	338
<b>B3</b>	304	304	304
<b>ød</b>	14	14	14
<b>h1</b>	235	235	235
<b>h2</b>	160	160	160
<b>L1</b>	650	650	650
<b>L2</b>	80	80	80
<b>L3</b>	440	440	440
<b>L4</b>	80	80	80
<b>L5</b>	6	6	6

## Dimensioni basamento

f1	ETN EVO 50 PP / ETFE	ETN EVO 60 PP / ETFE	ETN EVO 70 PP / ETFE
<b>Dimensioni motore</b>			
<b>80 (mm)</b>	175.5	175.5	175.5
<b>90 (mm)</b>	175.5	175.5	175.5
<b>100 (mm)</b>	175.5	175.5	175.5
<b>112 (mm)</b>	175.5	175.5	175.5
<b>132 (mm)</b>	193.5	193.5	193.5
<b>Forma motore</b>	<b>B5</b>	<b>B5</b>	<b>B5</b>
<b>Peso pompa (senza motore)</b>	60	60	60

\*L1 la dimensione è in accordo all'installazione del motore

\*\*Dimensioni flange secondo UNI 1092-2 ISO \ 7005-2 PN 16 RF tipo B - asolate ANSI 150 RF