

ETN evo

Overall dimensions

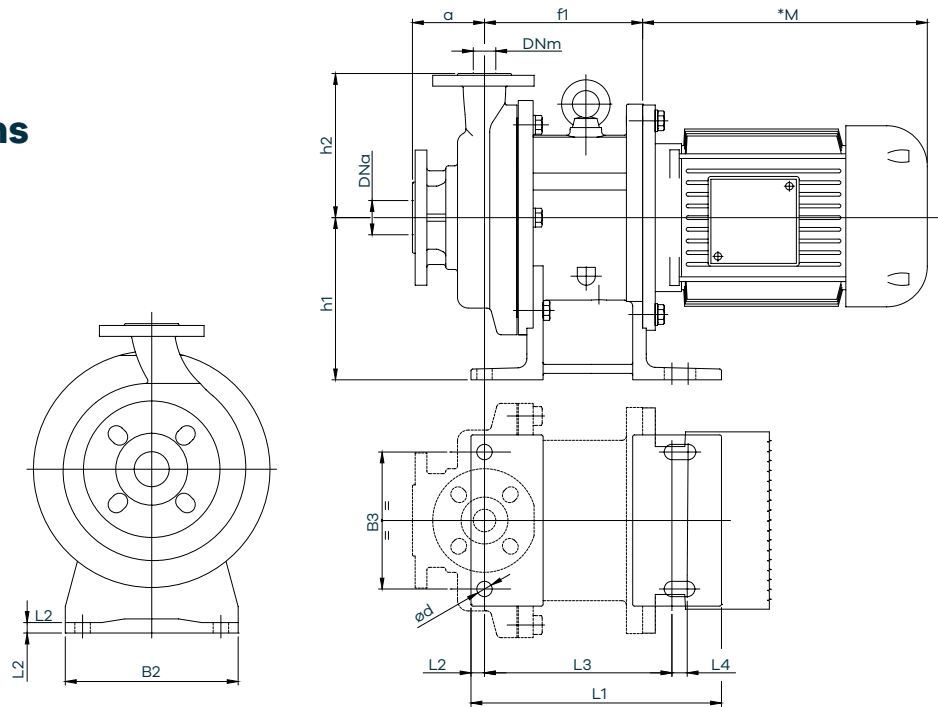

Pump dimensions

Model	ETN EVO 50 PP / ETFE	ETN EVO 60 PP / ETFE	ETN EVO 70 PP / ETFE
DN_a	40	65	80
DN_m	25	40	50
a (mm)	80	80	100
B₂	190	190	190
B₃	152	152	152
ød	17	17	17
h₁	180	180	180
h₂	160	160	160
L₁	277	277	277
L₂	15	15	15
L₃	208	208	208
L₄	17	17	17
L₅	11,5	11,5	11,5

f₁	ETN EVO 50 PP / ETFE	ETN EVO 60 PP / ETFE	ETN EVO 70 PP / ETFE
Motor dimensions			
80 (mm)	175.5	175.5	175.5
90 (mm)	175.5	175.5	175.5
100 (mm)	175.5	175.5	175.5
112 (mm)	175.5	175.5	175.5
132 (mm)	193.5	193.5	193.5
Motor shape	B5	B5	B5
Pump weight (without motor)	32	32	37

*L₁ the dimension is in accordance with the engine installation

**Flange dimensions in compliance with UNI 1092-2 ISO \ 7005-2 PN 16 RF type B - slotted ANSI 150 RF

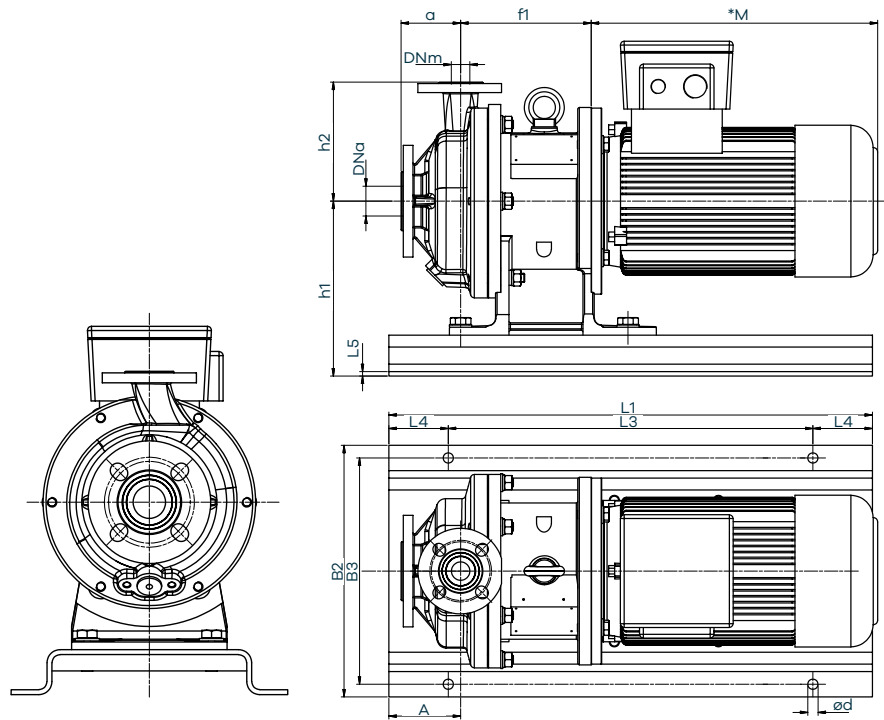

Pump dimensions

Model	ETN EVO 50 PP / ETFE	ETN EVO 60 PP / ETFE	ETN EVO 70 PP / ETFE
DNa	40	65	80
DNm	25	40	50
a (mm)	80	80	100
A	96,5	96,5	96,5
B2	338	338	338
B3	304	304	304
ød	14	14	14
h1	235	235	235
h2	160	160	160
L1	650	650	650
L2	80	80	80
L3	440	440	440
L4	80	80	80
L5	6	6	6

Base dimensions

f1	ETN EVO 50 PP / ETFE	ETN EVO 60 PP / ETFE	ETN EVO 70 PP / ETFE
Motor dimensions			
80 (mm)	175.5	175.5	175.5
90 (mm)	175.5	175.5	175.5
100 (mm)	175.5	175.5	175.5
112 (mm)	175.5	175.5	175.5
132 (mm)	193.5	193.5	193.5
Motor shape	B5	B5	B5
Pump weight (without motor)	60	60	60

*L1 the dimension is in accordance with the engine installation

**Flange dimensions in compliance with UNI 1092-2 ISO \ 7005-2 PN 16 RF type B - slotted ANSI 150 RF